

Physical Model Reduction of Antilock Braking System

Manarshhjet Singh, and Tarun Kumar Bera

Mechanical Engineering Department, Thapar University Patiala, Punjab, INDIA

Abstract: *Traction control system and Antilock Braking System (ABS) are used extensively in vehicles to control and enhance their performance. This is achieved by continuous monitoring of vehicle parameters and using on-off control to activate the system, so as to maintain the tyre slip ratio between the desired limits. As this is a continuous system, there is always a need to reduce the calculation time for cycle and to increase the overall cycle frequency. One of the approaches for achieving this is to identify the physical parameters which do not add much to the dynamics of the system. Hence, these elements if removed from the mathematical model do not disturb the results but can reduce the time of calculation and therefore the simulation time. This paper deals with discussion of such a technique using the bond graph modeling, obtaining the reduced system model of ABS and the comparison of the result of the full system with the reduced system.*

Keywords: *ABS, physical model reduction, eigenvalue separation, fast-slow dynamics, high-low frequency dynamics, bond graph.*

1. Introduction

Many of the systems that we use are very complex in nature. It is very difficult to obtain a complete solution to these problems. However, numerical simulation provides a highly successful method for the study of complex physical phenomenon. The problem with such methods is that, when the system is big, it becomes difficult to manage in the terms of controller design, parameter optimization, assessment under uncertainty and storage & computational requirements. Model reduction techniques are therefore used. The goal is to produce a low dimensional system for the existing one, such that, the response characteristics of the new system closely matches those of the original system. This reduces the problem to a manageable size and allows us to design cost effective controllers using simpler hardware.

Model order reduction can be done either by solving the full model and applying mathematical techniques to obtain the reduced form of results or by reducing the system to a reduced yet accurate form and then find the solution of the reduced model.

Rosenberg and Zhou [1] used bond graphs for measuring the power response obtained by applying a step input for a given time interval and calculating the power on all bonds of the bond graph. Then, a root mean square (r.m.s.) power in each bond was calculated. Finally, the bonds with low average values were eliminated from the bond graph model.

Louca et al. [2] preferred to employ energy as a measure instead of power as energy is the time integral of power and hence more advantageous when there are time-varying elements. The authors also claimed that the r.m.s. power can lead to inaccurate results due to heavy weightage of peak responses. Therefore, 'element activity index', a ratio of the energy flowing through an element to the total energy of system was defined. A major advantage of the method was that a reduced model could be obtained according to a frequency range of interest.

Another physical-based model technique by Sueur and Dauphin-Tanguy [3] made use of the singular perturbation method. The fast and slow dynamics of bond graph models were estimated by determination of causal loop gains and by utilizing reciprocal systems. The resulting reduced model was very near to the one deduced from the singular perturbation method.

Huang [4] discussed a method of utilizing Gersgorin theorem to reduce the system, by doing a preconditioning of the system matrix by selective arrangement of different elements to form different subsystems and then directly using these to get the fast and slow dynamics of the overall systems. As this

method required manual permutation of the elements to find an optimum set of subsystems, this turned out to be ineffective.

Orbak [5] used the technique of eigenvalue separation, to find different subsystems, which could be combined together according to the need, to get a desired reduced system.

The structure of this paper is as follows: First, the eigenvalue separation method, which is used in the reduction of the ABS model, is discussed, including the generalized procedure, graphical interpretation. Then, the mechanical equivalent of the ABS and its bond graph model are discussed. Finally, the model is reduced and a reduced bond graph model is obtained, which is compared with the full system model.

2. Model Reduction Techniques

The eigenvalue separation method is based on comparison of the energy exchange rates between two different elements. This rate of energy exchange depends on the loop gain containing these elements. The elements with very high exchange rates contribute to the faster subsystem. The subsystem which is obtained when the components of faster subsystem are removed and replaced with a zero source element is the slower subsystem. Hence, components that occur in loops of high gain are part of the faster subsystem and those which remain after the removal of the faster subsystem are part of the slower subsystem. If the energy exchange takes place between energy storing element and an energy dissipating element, fast and slow subsystem come into picture. If the energy exchange takes place between two energy storing elements, high frequency and low frequency subsystems dominate the system.

If the system has some of the loops containing only energy storing elements and some loops containing energy storing and energy dissipating elements, it becomes important to first identify the subsystems in which energy dissipation is quicker than energy exchange and subsystems in which energy dissipation is slower. These subsystems are called highly and lowly damped subsystems, respectively.

2.1. Procedure

Orbak [1] gave a method for recognizing high and low damped systems. For this identification, in addition to the loop gains for each energy storage element, the local damping ratios should also be calculated. For each directly causally related I-C pair in the system (with R elements causally connected to either I or C or both elements), the local damping ratios are given as $G_{RC}/2\sqrt{G_{IC}}$ and $G_{RI}/2\sqrt{G_{IC}}$ for the all C and I elements respectively. In these formulae, G_{IC} is the I-C loop gain, G_{RC} is the sum of the loop gains of R-C pairs and G_{RI} represents the sum of the loop gains of I-R pairs. This gives us the damping ratios of the system.

2.1.1. Identification of Heavily Damped Subsystems

1. All the C elements are replaced by flow sources of 0 values. The remaining R-I pairs, which are causally related directly are identified. These R-I elements and the involved junctions are denoted as part of a set called H.
Step 1 identifies the R and I elements that are responsible for the heavily damped modes, given that they affect the dynamics even if all of the capacitances are disabled.
2. The C elements are restored. The C Elements which are causally related directly to the above I elements are identified. If $\sqrt{G_{IC}} \gg G_{IR}$, then the C elements are replaced by flow sources with 0 value. These flow sources are denoted as part of the subsystem H.
3. The I elements that become dependent due to the causalities imposed by the above sources are identified and denoted as part of subsystem H.
Steps 2 and 3 identify the I elements that are involved in the heavily damped modes by the power transmission through I-C loops.
4. A similar procedure as step 1-3 is repeated by exchanging I with C and flow source with effort source and vice versa.
Step 4 repeats the same procedure for R-C elements.
5. The resistances which are involved in heavily damped local loops are identified. These R elements and the involved I-C pairs and junctions are denoted as part of the subsystem H.
Step 5 includes the over damped subsystems.

6. The C elements that are not involved above step, but are causally related directly to the above I elements, are identified. If $\sqrt{G_{IC}} \gg G_{IR}$, the C elements are replaced by flow sources with 0 value and these flow sources are denote as part of the subsystem H.
7. Repeat the step for I elements.
Steps 6 and 7 identify the I or C elements that affect the heavily damped modes by power transmission through other I-C loops.
8. Elements not present in H are removed. This gives us heavily damped system.

2.1.2. Identification of Lowly Damped Subsystems

1. The I-C pairs, which are involved in lightly damped local loops are identified. These I-C elements are denoted as part of a set called L.
2. The R elements that are not involved in step 1 but are causally related directly to the above I or C elements are identified. If $\sqrt{G_{IC}} \ll G_{IR}$ or $\sqrt{G_{IC}} \ll G_{IR}$, the resistive R elements are replaced by flow sources with 0 value and conductive R elements are replaced by effort sources with 0 value. These sources are denoted as part of the subsystem L.
3. The energy storage elements that become dependent due to the causalities imposed are identified and denoted in L.
4. Elements not present in L are removed. This gives us lowly damped system.

In this procedure, step 1 detects the lightly damped subsystems. Steps 2 and 3 identify I or C elements that are involved in the lightly damped modes considering the power transmission through the other I-R loops.

2.2. Generalised Procedure

First, the local damping ratios of the system are found. If all the local damping ratios are very small, the system can be treated as I-C system and decoupling can be done to find the high and low frequency subsystems. Similarly, if all the local damping ratios are very high, the system can be divided into fast and slow dynamic components. But, if in a system some of the local damping ratios are high, while the others are very low, the system must first be divided into heavily damped subsystem and lowly damped subsystem. Heavily damped subsystems can be decoupled into fast and slow subsystems while the lowly damped subsystem can be further subdivided into high and low frequency dynamics.

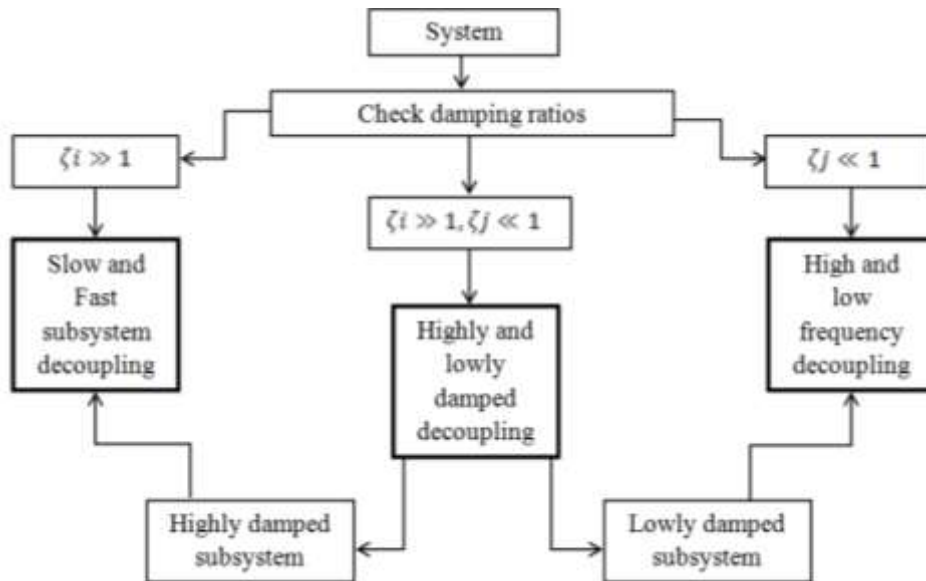

Fig. 1: Generalised Procedure for eigenvalue separation method.

2.3. Graphical Interpretation

Local damping ration discussed previously is the ratio of energy dissipation to rate of energy exchange between elements. A high energy exchange rate as compared to energy dissipation rate gives a very low local damping. This is equivalent to an oscillatory system which has eigenvalues near the imaginary axis. Similarly, a low energy exchange rate as compared to energy dissipation rate gives a very high local damping. This is equivalent to an asymptotic system which has eigenvalues near the negative real axis, considering only stable systems for simplicity.

As high damped system has Eigen values near the real axis it can be further divided into fast subsystem and slow subsystem. As fast subsystem dissipates energy faster it must have eigenvalues of higher magnitude than the slower subsystem. Similarly, as a low damped system has Eigen values near the imaginary axis it can be further divided into high frequency subsystem and low frequency subsystem. As high frequency subsystem exchanges energy faster it must have eigenvalues of higher magnitude than the low frequency subsystem.

3. Application

3.1. ABS Model Using Eigenvalue Separation Method

Antilock braking system is used in automobiles for an improved performance and better control over the vehicle. The objective of ABS is to maintain an optimal slip ratio [6]. The mechanical equivalent of ABS is given in Fig. 2. The schematic diagram for the logic is shown in Fig. 3.

The braking signal is actuated by the driver by pushing the brake pedal. At this point, the various sensors placed on the vehicle provide us with measurement of longitudinal speed of the vehicle and the angular speed of the wheels. By comparing these quantities, we can find the slip velocity and slip ratio. Slip velocity and slip ratio are expressed as

$$\text{slip ratio} = \frac{\dot{\theta}_w r - \dot{x}_w}{\dot{\theta}_w r} \quad - \quad \text{during traction} \quad (1)$$

$$= \frac{\dot{x}_w - \dot{\theta}_w r}{\dot{\theta}_w r} \quad - \quad \text{during braking} \quad (2)$$

Initially, the angular speed of wheel decreases before there is a decrease in the longitudinal speed of vehicle. This increases the slip ratio. At high value of slip ratio, the grip between road and tire decreases, so when the slip ratio reaches a predefined maximum value, the braking torque is released. Similar to conditions of high slip ratio, a low slip ratio also decreases the grip between road and tire. So, if slip ratio drops to a predefined minimum, the braking torque on the wheel is increased.

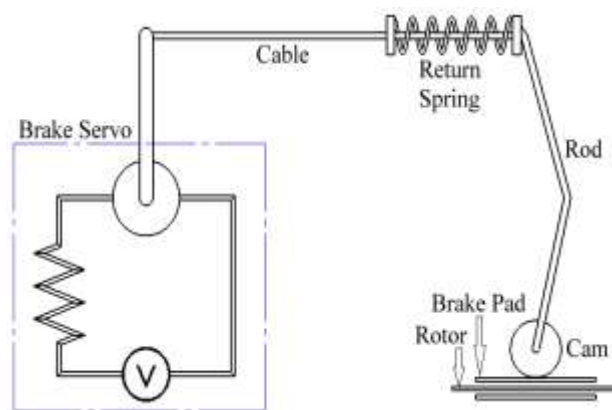

Fig. 2: Schematic diagram of ABS [6].

The ABS model is simulated to operate at voltage to produce a braking torque of 100 Nm, and is connected to a wheel having a moment of inertia of 15 kg m². Arm length $l_a = 1$ m, $R_{lm} = 0.04$ Ns/m, $K_{ca} = 104$ N/m, $K_{re} = 106$ N/m, and the wheel has a radius of 0.15 m.

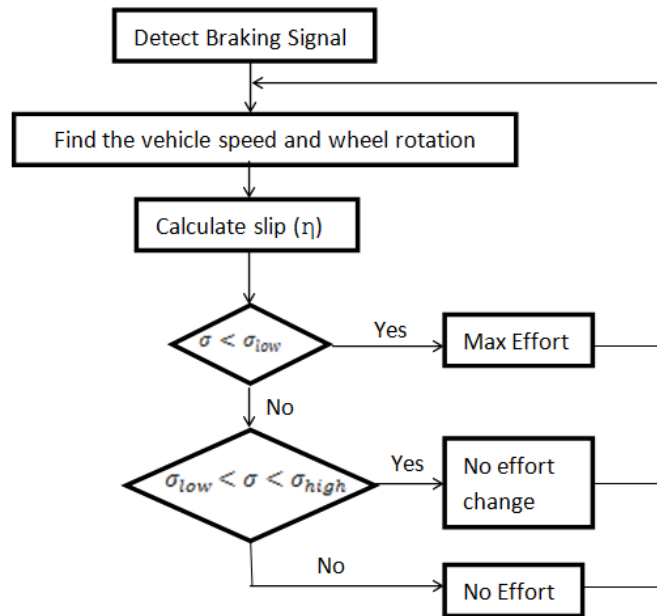

Fig. 3: Operation logic of ABS [6].

R_{lm} and K_{ca} are the elements associated with loop with high loop gain. These form the major components in the fast subsystem. But, it is observed that the fast subsystem does not contain the component of interest i.e. wheel. Hence, we also find the slow subsystem. Slow subsystem is shown in Fig. 4(b). The physical interpretation is that the exchange of energy between R_{lm} and K_{ca} is too high and dissipates before any observable effect, hence, slow system can be used as an approximation for all times.

TABLE I: Causal Loops in ABS Bond Graph Model

Loop No.	Loop	Loop type	Loop Gain
1	R_{lm} - K_{ca}	RC	25000
2	J_w - K_{ca}	IC	3.8729
3	J_w - K_{re}	IC	38.729

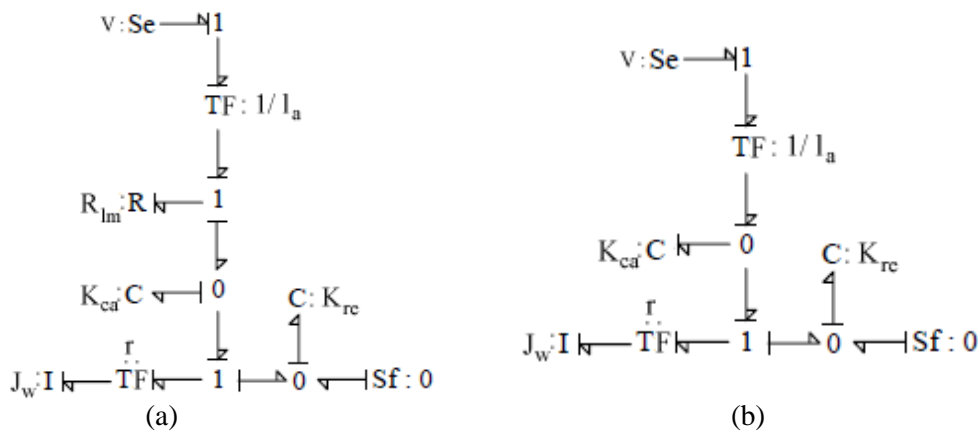

Fig. 4: Bond graph of (a) full system and (b) reduced system.

The full system and reduced system were compared by observing the torque given to the wheel. The difference between results of the models was plotted and is shown in Fig. 5. The reduced system gives very close results as compared to the full system.

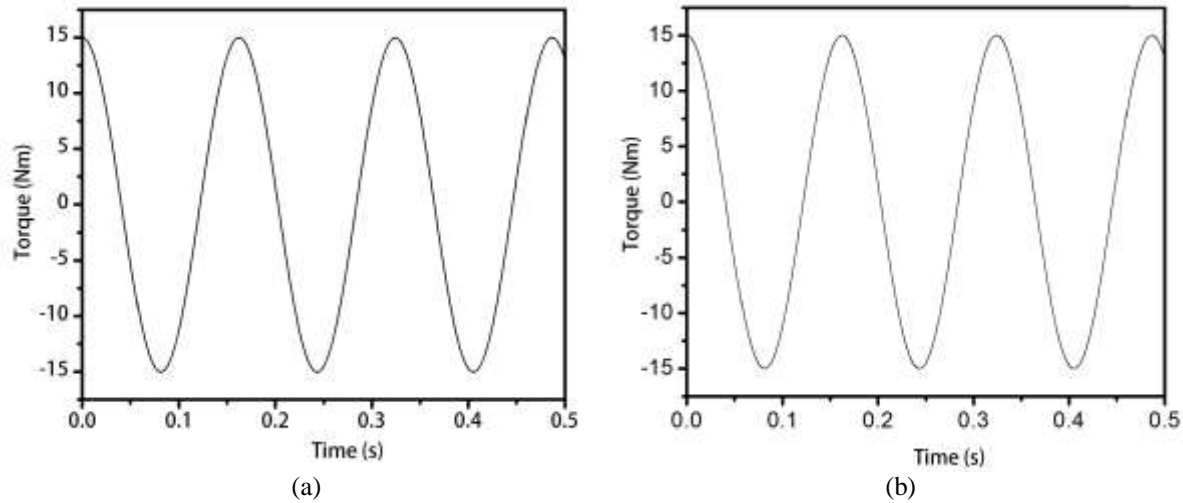

Fig. 5: Comparison of torque given to the wheel using (a) full model and (b) reduced model.

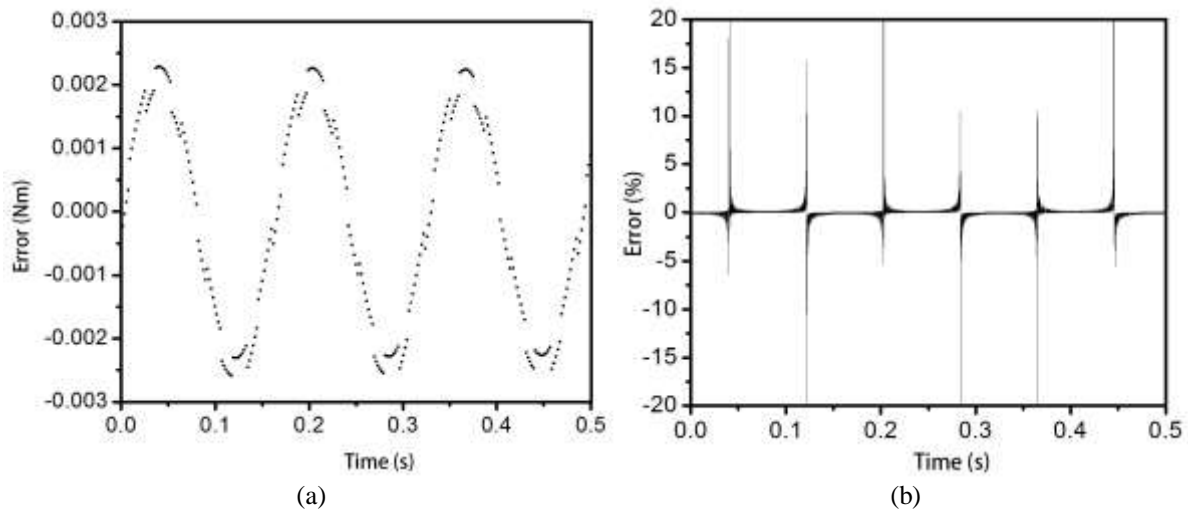

Fig. 6: (a) Absolute error (b) percentage error in torques for full and reduced model.

Figure 5 shows the comparison of braking torque achieved from the full and reduced ABS models. The results are very close and can be considered within the error limits of computation. But from the Fig. 6(b), we observe that the percentage error of the system follows a cyclic variation and reaches a value $\pm 20\%$, but such an error is not observed when comparing the torque directly. It is observed that error percentage increases on times when the torque given to the wheels is closer to zero. So, a percentage error compared to such a small base term gives a high percentage of error, even if the error is within acceptable limits in absolute terms. This can be observed from Fig. 6(a), which shows the absolute error in torque given to the wheel for full and reduced model.

4. Conclusions

In this paper, a method of reducing the system in physical domain, using the property of eigenvalue separation is utilized to reduce the number of elements that are required to solve the model. The loop gains of the loops containing R1m are very high indicating a quick dissipation of energy in the element. So, this element was removed to obtain the slow subsystem, which is the required reduced subsystem. The reduced model conserves the dynamics of the system, but reduces the amount of calculations and time requirement for simulation to match with the actual system. The calculations can be reduced further, by using mathematical reduction models for solving the system.

5. Acknowledgements

Research in this area is supported by University Grants Commission, New Delhi in the framework of Design and Control of Intelligent Autonomous Vehicle (IAV) for Indian Sea Ports.

6. References

- [1] R. C. Rosenberg, and T. Zhou, "Power based model insight," presented at ASME Winter Annual Meeting on Automated Modeling for Design, Chicago, Illinois, Nov 27- Dec 22, 1988.
- [2] L. S. Louca, J. L. Stein, G. M. Hulbert, et al. "Power model generation: an energy-based methodology," presented at 3rd International Conference on *Bond Graph Modeling*, Phoenix, Arizona, Jan 1997, vol. 29, no. 1, pp. 44-49.
- [3] C. Sueur, and G. Dauphin-Tanguy, "Bond graph approach for multi-time scale system analysis," *J. Franklin Inst.*, vol. 5, pp. 1005-1026, 1991.
[http://dx.doi.org/10.1016/0016-0032\(91\)90066-C](http://dx.doi.org/10.1016/0016-0032(91)90066-C)
- [4] S. Y. Huang, "Structural Analysis from System Configurations for Modelling and Design of Multi-Energy Domain Dynamic Systems," Ph.D thesis, Dept. Mech. Eng., Massachusetts Institute of Technology., Cambridge, U.S.A, 1997.
- [5] A. Y. Orbak, O. S. Turkay, E. Eskinat et al., "Model Reduction in the Physical domain," in *Proc. 2003 Institution of Mechanical Engineers, Part I: Journal of Systems and Control Engineering*, 2003; pp. 481-496.
- [6] T. K. Bera, K. Bhattacharya, A. K. Samantaray, "Evaluation of antilock braking system with an integrated model of full vehicle system dynamics," *Simulation Modelling Practice and Theory*, vol. 19, pp. 2131–2150, 2011.
<http://dx.doi.org/10.1016/j.simpat.2011.07.002>